

Greenhouse Energy Conservation Checklist/Audit

(Adapted by A.J. Both, Rutgers University, and Paul Fisher, University of Florida from a checklist developed by John W. Bartok Jr., Professor Emeritus, University of Connecticut) 2006

Structure #/name _____

Approximate year built _____

Dimensions and space use

Size: total width _____ ft. bay width _____ ft. number of bays: _____ length _____ ft.

Square feet of floor space: _____ Sq. ft. of bench/floor space covered by crops: _____

% Space utilization (floor area used for crop production/total floor space)? _____

Number of hanging baskets: _____ Sq. ft. of floor space per hanging basket: _____

List main crops [in general groups (e.g., plugs)] grown in the greenhouse at different times of year:

Crop type	Months	Sq. ft. of greenhouse space filled

Is the greenhouse used for production? _____ retail? _____ both? _____

Are crops grown on floor _____, benches _____, overhead _____.

Are plants grown in one or multiple levels (e.g., hanging baskets)? Yes No

Is a roll-out bench system used for spring bedding plant production? Yes No

Is the greenhouse completely filled with plants during the time it is heated? Yes No

Suggestions (consult an expert) to improve space utilization: _____

Perimeter insulation

Has perimeter insulation been installed? Yes No

If yes, what material, how thick and to what depth? _____

If applicable, are knee walls (or side walls to bench height) insulated? Yes No NA

Is the wall area directly behind side wall heating pipes insulated? Yes No NA

What is the condition of the various insulation materials? Excellent Good Fair NA

Suggestions (consult an expert) on perimeter insulation: _____

Heating system (Note: calculation methods are provided at the end of this document)

What type of heating system is used? Hot water Hot air Steam Other

What is the manufacturer and model of the heating system? _____

What is the total installed capacity of the heating system? _____

What is the designed delta T (inside temperature minus coldest outside temperature)? _____

What is the total calculated heat requirement (calculate yourself or ask manufacturer)? _____

Is the installed capacity adequate, given the heat requirement and desired delta T? Yes No

What fuel source(s) is(are) burnt in the boiler/heaters? _____

Does the grower use floor and/or bench heating? Yes No

Is the temperature sensor or thermostat shielded from sunlight? Yes No

 in an aspirated box? Yes No

 within 3 feet of the crop canopy? Yes No

 at a representative location along the house? Yes No

 calibrated in the last 12 months? Yes No

If the grower uses a thermostat, what is its accuracy? ± °F

 is it an electronic thermostat? Yes No NA

Are HAF fans installed and in use? Yes No

 commercial grade or residential house fans? Commercial Residential

 turned off when venting air? Yes No

Insect Screening

Is the ventilation opening outfitted with insect screening? Yes No

If yes, what is(are) the type(s) of insect(s) that need to be screened out? _____

If yes, what is the mesh size (or opening size) of the screen material? _____

If yes, what is the pressure drop across the screen material? Inches of water gauge _____

If yes, is the insect screen in good condition (i.e., without unwanted openings)? Yes No

If yes, how often is the screening material cleaned?

If yes, does the ventilation system provide adequate ventilation on warm summer days?
Yes No

If no, does the grower report insect problems? Yes No

Suggestions (consult an expert) in terms of insect screening: _____

Drainage

Does rain and melt water drain away from the building properly? Yes No

Is there excess irrigation water on the floor Yes No

Suggestions (consult an expert) in terms of drainage: _____

Conserving Electricity

Are all electrical motors high efficiency? Yes No

Were any incandescent lamp bulbs replaced with fluorescent or HID bulbs? Yes No

Was a licensed electrician involved in design of the system Yes No

Has the entire electric system been checked recently by a licensed electrician? Yes No

How many phases does the electric system have? _____

What is the voltage provided to the various electrical services? _____

Is there a backup generator? Yes No

Suggestions (consult an expert) in terms of electricity: _____

Equations, figures and tables useful for heat calculations:

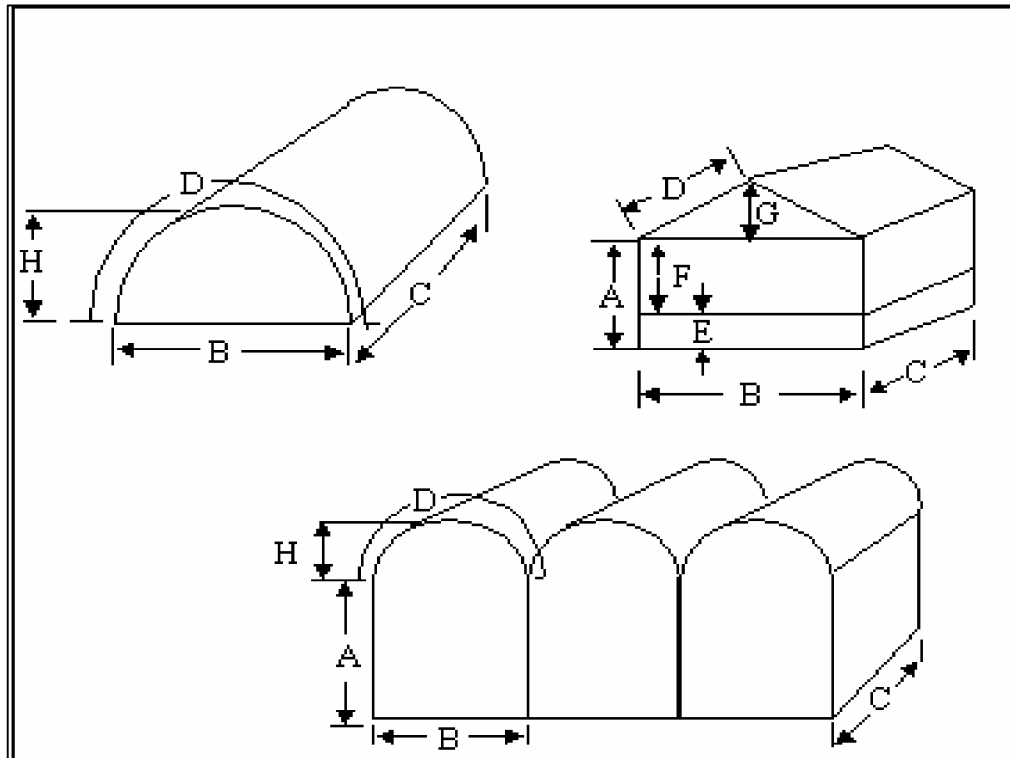

Step 1: Determine greenhouse dimensions (in feet).

Wall height A =

House width B =

House length C =

Rafter Length D =

Lower wall height E =

Upper wall height F =

Gable height G or H =

Step 2: Calculate surface areas (in ft²) and perimeter distance (in ft)

Note: N is the number of greenhouse bays. N = 1 for a single bay greenhouse.

Lower side wall area: $2N(E \times B) + (E \times 2C) =$

Upper side wall area: $2N(F \times B) + (F \times 2C) =$

Or, Single material side wall: $2N(A \times B) + (A \times 2C) =$

Gable-style greenhouse roof surface area: $2N \times D \times C =$

Gable-style greenhouse gable area (end wall above gutter): $N \times B \times G =$

Curved-roof style greenhouse roof surface area: $N \times D \times C =$

Curved-roof style greenhouse gable area (end wall above gutter): $1.1N \times B \times H =$

Hoop-house end wall area: $1.5N \times B \times H =$

Perimeter: $2[(N \times B) + C] =$

Step 3: Determine U-values for each material used in the various surface areas.

Lower wall area: $U_1 =$

Upper wall area: $U_2 =$

Single material wall: $U_3 =$

Greenhouse Energy Conservation Checklist/Audit

End wall area: $U_4 =$

Roof: $U_5 =$

The U-values (heat transfer coefficients) can be determined from the data shown in the table below.

Material	U in Btu/hr per ft ² per °F
Single (double) layer of glass	1.1 (0.7)
Single (double) layer of poly	1.1 (0.7)
Double layer plus energy curtain	0.3 – 0.5
Double layer acrylic	0.6
Double layer polycarbonate	0.6
½" plywood	0.7
8" concrete block	0.5
2" Polystyrene	0.1 (R = 10)

Step 4: Calculate the structural heat loss (Q_{STRUC} in Btu/hr)

$Q_{STRUC} = \sum(U_i \times A_i) \times \Delta T$ (i.e., the sum of all applicable heat losses)

Heat loss from lower wall area: Lower side wall area $\times U_1 \times \Delta T =$

Heat loss from upper wall area: Upper side wall area $\times U_2 \times \Delta T =$

Or, Heat loss from single material wall area: Single material side wall area $\times U_3 \times \Delta T =$

Heat loss from gable or curved-end area: Gable or curved-end area $\times U_4 \times \Delta T =$

Heat loss from roof area: Roof area $\times U_5 \times \Delta T =$

Total $Q_{STRUC} =$

ΔT is the temperature difference between inside and outside, or the difference between the nighttime temperature set point (inside) and the local minimum design temperature (outside). This minimum design temperature can be determined for a particular location from historical weather data, or estimated from the figure shown below.

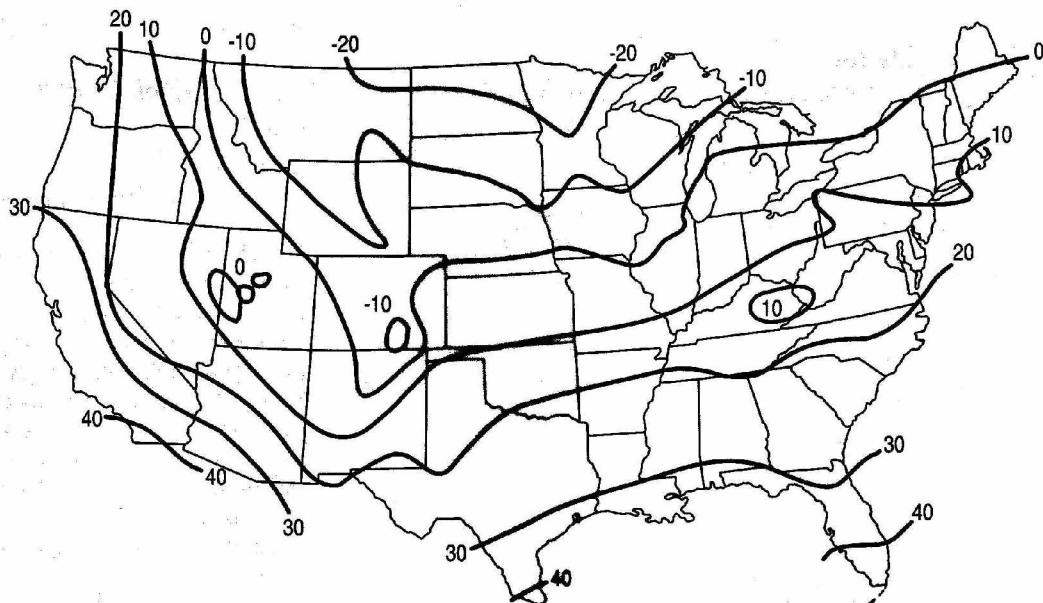

Step 5: Calculate the perimeter heat loss (Q_P in Btu/hr)

$Q_P = \text{Perimeter heat loss factor} \times \text{Perimeter} \times \Delta T$

For perimeter heat loss factor, use a value of 0.4 or 0.8 Btu/hr per linear foot of perimeter per °F depending on whether the perimeter is insulated or not.

Step 6: Calculate the greenhouse volume (in cubic feet)

Gable-style greenhouse volume: $N[(A \times B \times C) + (B \times G \times C/2)] =$

Single curved roof greenhouse volume: $2H \times B \times C/3 =$

Multiple curved roof greenhouse volume: $N[(A \times B \times C) + (2H \times B \times C/3)] =$

Step 7: Calculate the infiltration heat loss (Q_A in Btu/hr)

$Q_A = 0.02 \times \text{Greenhouse volume} \times \text{Air exchanges per hour} \times \Delta T =$

For air exchanges per hour use the following table.

<i>Type of construction</i>	<i>Air exchanges per hour</i>
New, glass	0.75 - 1.5
New, double poly	0.50 - 1.0
Old, glass and in good condition	1.0 - 2.0
Old, glass and in poor condition	2.0 - 4.0

Step 8: Calculate the total heat loss (Q_T in Btu/hr)

$Q_T = Q_{STRUC} + Q_P + Q_A =$

Adjustment to the heat loss calculations should be made for situations with a large ΔT and/or locations with high average wind velocities: If ΔT is larger than 70°F, and if the average wind velocity is larger than 15 mph, multiply the calculated total heat loss by: (1 + 0.08) for every increase in ΔT of 5°F above 70°F and (1 + 0.04) for every 5 mph increase in average wind velocity above 15 mph. For example, if $\Delta T = 80^\circ\text{F}$ and the average wind velocity is 25 mph, multiply the calculated total heat loss by a factor of: $1 + (0.16 + 0.08) = 1.24$.

If the greenhouse heating system is designed properly, the capacity of the heating system should match the calculated total heat loss Q_T (that is the predicted heat loss on the coldest night). Make sure that the heating system has an output rating that equals the calculated total heat loss. When the heating system is rated by input, multiply this value by the efficiency of the system (generally in the 70-80% range) to determine the rated output.

Additional reading:

Aldrich, R.A. and J.W. Bartok. 1994. Greenhouse Engineering, NRAES Publication No. 33. Natural Resource, Agriculture, and Engineering Service. P.O. Box 4557 Ithaca, NY 14852. <http://www.nraes.org>.

Bartok, J. W. 2001(revision). Energy Conservation for Commercial Greenhouses. NRAES Publication No. 3. Natural Resource, Agriculture, and Engineering Service. P.O. Box 4557 Ithaca, NY 14852. <http://www.nraes.org>.